



Installation and maintenance instructions for liquid-filled distribution transformers



Contents

Caution	4
1. Generally applicable conditions	5
1.1. Warranty conditions	5
1.2. Transportation	6
1.2.1. Transportation by truck	6
1.2.2. Transportation by rail or sea	6
1.2.3. Moving distribution transformers	6
1.2.4. Acceptance procedure	7
1.3. Storage	8
1.3.1. Preparation and checking of transformers before storage	8
1.3.2. Monitoring and checking of transformers during storage	8
1.3.3. Storage after taken out of operation	8
2. Installing and connecting liquid-filled distribution transformers	9
2.1. Installation	9
2.2. Connections	9
2.3. Earthing	10
3. Putting into operation	11
3.1. External check	11
3.2. Electrical measurements before putting into operation	12
3.3. Energizing	12
3.4. Parallel operation	14
4. Maintenance	15
4.1. Annual external check	15
4.2. Two-yearly maintenance	15
5. Liquid sampling and analyses	16
6. Pauwels Transformers NV After Sales Service	17
7. Accessories	18
8. Standards	19
9. End of life	20
Annex 1: Insulation resistance measurement (Megger test)	21
Annex 2: Recommended torque values in Nm for various connections	22

CAUTION

When lifting or moving the transformer, care should be taken to ensure that the bushings, the cooling fins and the other accessories are not damaged by the lifting apparatus, pulling tools or adjacent obstacles.

Before energizing the transformer, a basic visual electrical & mechanical component check up should be completed. Check that:

- > The transformer is not damaged;
- > The fins are not damaged;
- > There are no oil leaks;
- > The paint is not damaged;
- > The bushings & accessories are not damaged.

Never open a hermetically sealed transformer. Please contact our After Sales Service department for instructions. Never open such a transformer at oil temperatures higher than 20°C (thermometer pocket reading) since hot oil may be ejected.

The tap-changer handle must not be operated when the transformer is energized (must be OFF-CIRCUIT)!

In case of presence of an expansion tank: remove the gasket from the fitted breather or replace the blind flange and install the breather.

Refer to the Technical Data Sheet (TDS) and Material Safety Data Sheets (MSDS) for all safety measures and precautions with regard to fire hazard, exposure to skin or contamination of materials such as the cooling liquid and paints.

It is essential that only authorized, properly trained and competent personnel are allowed to operate, inspect or carry out maintenance activities after all appropriate safety measures and precautions have been established. It is absolutely essential to ensure that the circuits for equipment under maintenance or periodic checking are dead. Precautions must be taken to prevent the energizing of circuits under check, maintenance or repair, while personnel are working on the equipment.

We accept no responsibility for any damage resulting from the incorrect operation of the equipment or disregard of the information contained in these instructions.

Under certain circumstances, disturbances may occur with the equipment in service which are not dealt with in these instructions. In such cases, please consult us at the address given previously. The lifetime of the various components depends upon proper care and maintenance. It is necessary that maintenance personnel have documents of the relevant parts to ensure that checks are carried out in accordance with the appropriate instructions. The servicing intervals and other specific instructions given in the relevant equipment manuals must be followed if reliable long life of the components in service is to be achieved.

Ensure that only suitably qualified personnel carry out the installation, operation and maintenance of Transformers. Local / site operating procedures take precedence over the operating instructions given in this manual

1. Generally applicable conditions

We are delighted that you have purchased a Pauwels' transformer. It was manufactured using the latest techniques, tested in full and subjected to a thorough final inspection before delivery. In spite of these precautions difficulties may still arise during transportation, installation or operation. That is why we advise you to read the following instructions carefully.

A transformer is an electrical appliance and should therefore be handled according to the applicable national safety instructions.

Remarks:

This manual applies to liquid-filled "Distribution Transformers" which covers the range of transformers up to some 10MVA/36kV, not only used for distribution of electricity but also for energy supply to light industry and generator step-up applications.

This range typically uses transformers with finned tanks. If you have opted for a transformer tank with radiators, other instructions are partly applicable. Consult us about these.

This manual applies to liquid-filled transformers in which the liquid can either be:

- > Mineral oil as per IEC 60296;
- > Silicone fluid as per IEC 60836;
- > Synthetic ester as per IEC 61099;
- > Natural (vegetal) ester as per IEC 62770.

1.1. Warranty conditions

The transformer typically comes with a factory warranty against construction defects that applies for 12 months after being put into operation, with a maximum of 18 months after leaving the factory. Any deviations from this must be established contractually. The warranty is limited to the repair or possible replacement of the transformer and this repair or replacement does not extend the original warranty. If difficulties arise during the warranty period and afterwards, the service department of Pauwels Transformers NV can be contacted. They will give you the necessary support or assistance. The transformer has been designed to operate in the conditions as in the associated technical specifications. Special attention is to be taken prior to energizing that the actual operating conditions and environment (such as ambient temperature, direct exposure to sunlight, moisture, operating altitude, frequency, transients, etc..) are within the specifications of the contract as any use outside these limits will render the warranty as void.

In case of any interpretation disputes, the 'General terms and conditions of sale' of Pauwels Transformers NV shall take precedence over these instructions and the 'Special agreements' shall take precedence over the 'General terms and conditions of sale'. Upon request, evidence with records of full adherence to this manual instructions must be provided as a pre-requisite for any warranty performance and/or liability. Only qualified staff that is certified and capable of understanding and executing the instructions, pre-cautions and measurements on the transformer are allowed to perform any undertaking on the transformer as a pre-requisite for any warranty offering from Pauwels.

1.2. Transportation

Distribution transformers are shipped 'ready for installation', which means filled with the insulating liquid and with accessories fitted (or occasionally supplied separately).

1.2.1. Transportation by truck

The transformers must be tightly secured at the top and bottom on the truck. At the bottom by nailing down the skid, by using rubber mats or other means; fixed rollers should be clamped. The transformer must be tightly secured at the top via the lifting lugs or via special transport securing lugs. If securing straps are used, make sure they do not pull on the fins or fin reinforcements. If the transformer is fitted with an expansion tank and a silica gel breather, see paragraph 1.2.2. about hermetic sealing.

1.2.2. Transportation by rail or sea

Transformers are usually packed in sturdy crates, boxes or containers. When packed in crates, the transformer's lifting lugs can be used to lift the entire equipment. Under no circumstances may moisture be allowed to penetrate into the transformer. For hermetically sealed transformers – those with gas cushions as well as those with integral filling – this is not a problem. The liquid cannot come into contact with the surrounding air. For transformers with an expansion tank the infiltration of air during transportation and storage is prevented by:

- > Either placing a gasket in the de-aerator (breather) cap (which must be removed before the transformer is energized);
- > Or replacing the silica gel air breather by a blind flange that prevents the infiltration of air. In that case the air breather is supplied separately. Assembly instructions are included with the air breather.

1.2.3. Moving distribution transformers

In order to move a transformer the following accessories are required, depending on the transformer's size and the directions:

- > A set of rollers, the wheels of which can be changed very simply in a longitudinal or diagonal direction;
- > Lifting lugs on the main cover;
- > Reinforcement of the bottom of the transformer tank allowing transportation by forklift, and;
- > If necessary, upon special request, jacking bosses and/or (fixed or detachable) lugs on the roller base or carriage.

Attention: Never lift a transformer under the cooler fins. Never use the bushings (high voltage (HV) or low voltage (LV) insulators) to guide the transformer when moving it. Nor should the fins or fin reinforcements (round bar on top and bottom of the fins) be pulled on.

The securing lugs are not to be used to manipulate the transformer; they must be used exclusively to secure the transformer during transport.

1.2.4. Receipt and Acceptance procedure

Upon arrival of a transformer and its accessories everything should be closely inspected.

The following points should be checked:

- > Is the crate or box damaged?
- > Is there rust or is the paint on the transformer or its accessories damaged?
- > Are the transformer tank or accessories damaged?
- > Are there leaks?
- > If the liquid level is visible, is it high enough?
- > Is the delivery complete? Check the number of transformers, the number of boxes of accessories and check that all accessories are fitted or present;
- > Check the information on the rating plate.

All deviations should immediately be marked on the delivery note (CMR) and should immediately be reported to Pauwels Transformers NV. If no report has been received within 24 hours of arrival at the customer's, it shall be assumed that the delivery arrived complete and in good condition.

In connection with transportation insurance, the following procedure is to be applied in the event of damage:

- > If no transportation by sea preceded transportation by land and you did not receive an insurance certificate:
 - Declare the transport company liable by means of a comment on the delivery note and a registered letter;
 - Do what is necessary to limit the damage and to avoid additional damage;
 - Inform Pauwels Transformers NV.
- > If transportation by sea preceded transportation by land and/or you received an insurance certificate:
 - Follow the instructions on the back of the insurance certificate carefully. Do not sign a 'clean' proof of receipt, but record your reservations on these documents;
 - Inform Pauwels transformers
- > In case of transportation by rail: have the authorities at the station the delivery was collected from draw up a report. This acceptance procedure must be repeated after each transportation stage, so that the origin of the damage can be established.

1.3. Storage of transformers

1.3.1. Preparation and checking of transformers before storage

- > If an air breather is provided, it must be fitted and filled with dry (orange) silica gel. Fill the oil lock and fit it under the air breather. The liquid level is checked and, if necessary, liquid is added. For more information about this, see chapter 4 'Maintenance'.
- > Any damage to the paint is touched up. Contact Pauwels Transformers NV for the correct procedure.
- > If a Buchholz relay is provided, the transport protection (test button lock) is removed.
- > If an explosion vent is fitted, replace the blank plate by the foil membrane.

Storage is limited to 1 to 2 weeks. If it lasts longer than this, the expansion tank and, if provided, the air breather must be installed and the transformer must be filled or topped up with the liquid provided. Storage should preferably occur in a dry, ventilated area, unless the transformer is protected by a condensation-free cover.

1.3.2. Monitoring and checking of transformers during storage

Preferably only fully assembled, liquid-filled transformers are stored for a long period of time. The following checks must be carried out during storage:

- > Check the air breather, if fitted. Check the status of the silica gel (its color indicates whether it is dry (orange) or wet (transparent); see chapter 7 for technical data on accessories). Check the level of the oil lock;
- > Check the transformer for leaks;
- > Check that there is no damage to the paint and that there is no rust.

If any defects are established, they should either be remedied immediately or Pauwels Transformers NV should be informed as quickly as possible.

1.3.3. Storage after being taken out of operation

Before the transformer is stored, a full check as described in the 'Acceptance procedure' paragraph should take place. Responsibility for correct storage lies with the customer. Attention should be paid to the following:

- > The possibility for the liquid to expand must be guaranteed;
- > Contact of the liquid with the air must be avoided;
- > The transformer must always be stored filled with liquid.

2. Installing and connecting liquid-filled distribution transformers

The following instructions are intended to be used by skilled personnel trained to work with transformers and electrical equipment, and do not claim to be complete down to the smallest detail. All work must be performed by skilled personnel, or by skilled subcontractors qualified to work on electrical systems. Pauwels explicitly disclaims all responsibility or liability for any direct or indirect damage due to improper erection or operation of the transformers, or caused by unauthorized interference with safety features, etc., even though such points are not specially mentioned in these operating instructions. During installation the following rules must be followed in order to ensure that the transformer operates correctly:

2.1. Installation

The local regulations for installing liquid-filled transformers in buildings, on a pole, in a cabinet or in the open air must be followed to the letter in relation to, among others, fire safety, protection against leaking (sump or oil-retaining tank), accessibility, electrical regulations,...

The place where the transformer is set up must be adequately ventilated in order to enable dissipation of the heat given off by the transformer. We are at your disposal to do relevant calculations and to explain the precautions that need to be taken. For distribution transformers set up in buildings or steel sheet substations this implies a regular supply of fresh air from outside, adequate ventilation and enough free space in all directions around the transformer.

Liquid sample plug, tap changer and any other operating and protection equipment must be easily accessible. Monitoring apparatus such as thermometers must be clearly visible and/or readable.

Setting up the transformer completely parallel with a wall is not advisable as this may increase the noise. Anti-vibration pads under the wheels may reduce the transfer of noise vibrations to the ground. The area in which the transformer is placed must be inaccessible to pets, birds, rodents, ...

We once again remind you that lifting the transformer under the cooling fins is absolutely forbidden. This will create leaks.

2.2. Connections

Electrical and other connections.

Always ensure that connection of the cables and busbars to the bushings is done without any tensile force being exerted on the bushings that can lead to leakage by the gasket or cracks in the bushings. A flexible connection is highly recommended in all cases. In this way, expansion of the conductors due to temperature differences cannot lead to leaks or cracks. Torque values to be used: see table in Annex 2.

When using plug connections on the HV, the instructions of the manufacturer of the connectors are to be observed.

To avoid any stress on the plug connection, the HV cables should be supported within 50 cm from the plug connection. The first 50 cm of the cable should not be bended, after this distance the bending radius as per instructions of the cable manufacturer should be respected.

Ensure that all connections have large, solid and clean contact surfaces. When connecting different materials, precautions should be taken to avoid electrolytic couples. These connections can be made using cable lugs, flat busbars or adapted clamps. Each feeder conductor must have a sufficiently large section.

Whenever the transformer's HV and LV porcelain bushings are worked on, it must be ensured that the lower nut on the bushing remains in position. This ensures that the transformer remains sealed. Use 2 spanners when tightening the other nuts on the bushing to prevent the bushing from twisting.

2.3. Earthing

The transformer tank must be connected to the HV earthing system. Therefore earthing bosses are fixed onto the cover, the roller carriage or the base of the transformer tank. The electrical resistance of the earthing terminal is usually specified by the power supply company. Ensure that the connection point is kept clean. The cross-section of earthing connections must be according to regulations and conditions on site.

3. Putting into operation

After setting up and connecting the transformer, the following steps must be carried out sequentially to put it into operation and a check-list to allow verification is to be kept:

3.1. External check

- > Check that the various transport protection measures have been removed: Buchholz test button lock, air-breather plugs, seal in filler cap of expansion tank, polystyrene blocks in cooling fins, ...
- > Check the ambient temperature and ventilation of the premises.
- > Check for leaks, rust and damage; (check that the drain plug does not leak, that the sampling plug and any filter press valves are completely closed).
- > Check the setting up and operation of the various accessories; dial plates of measuring apparatus and the color of the silica gel in the air-breather, if present, must be visible and readable at a safe distance from the live parts.
- > Check the color of the silica gel (if applicable) since this indicates its dryness. If needed, the silica gel must be dried or replaced. See the PK-document 3750 listed in chapter 7.
- > Check the liquid level via the oil level indicator (if applicable).
Attention: Never top up a hermetically sealed transformer yourself as there may be overpressure or under pressure in the transformer tank.
- > Check whether bushings, apparatus and control units are dirty. They must be clean at all times.
- > Open HV and LV air-filled cable boxes: check for condensation, water penetration and leaks.
- > Check the compound level in the HV cable junction box (if applicable).
- > Tighten all bushings and electrical connections, including those in the boxes, using a torque spanner; see chapter 2.2. 'Connections'.
- > Check that the transformer is properly earthed.
- > Remove all foreign objects from the conductors, from the cover and from the cable boxes. If the transformer is located in a distribution station or substation, all foreign objects must be removed from this area.
- > In case of dual voltage on the LV and/or HV side, check that the connecting strips or change-over switches are in the correct position to form the required connection group and voltage.

Over voltages can occur due to switching and external atmospheric conditions. External atmospheric over voltages may in many cases reach such values that not even a transformer with impulse voltage strength in accordance with the standards can withstand them. The transformer must be provided with protective devices against these over voltages. In accordance with insulation co-ordination principles the protective levels determined by these devices should be within reason below the endurance level of the transformer.

3.2. Electrical measurements before putting into operation

All transformers that leave the factory have been submitted to the routine tests and measurements in accordance with IEC 60076, and a test certificate is issued.

Ensure that only suitably qualified personnel carry out the measurements and measurement records are to be maintained for verification, upon request.

Pauwels. Pauwels Transformers NV specifies the following tests:

- > An insulation test using a 2500 or 5000 Volt 'Megger' (see Annex 1);
- > A continuity test of the connections and windings, and;
- > A check of the auxiliary devices and accessories (correct operation, setting and checking of the contacts, cabling, checking of test equipment).

Attention: Never pressurize transformers to check the pressure valve and/or pressure relay.

If it is suspected that a transformer has been damaged during transportation, for instance if any external damages have been observed, the following additional measurements have to be carried out on the entire batch of delivered transformers prior to energizing :

- Winding resistance
- Transformer ratio
- Oil analysis with moisture content.

Sufficient qualified personnel must be available at the user of a user's subcontractor to perform these measurements and dated and named evidence records needs to be provided to Pauwels prior to energizing.

3.3. Energizing

Energizing should be carried out by an authorized person and the locally applicable safety instructions should be observed a check-list to allow verification is to be kept

Conditions for Energizing

The recommended pre-commissioning checks must be carried out before energizing the transformer and a record check-list is to be maintained. The transformer should be initially energized without load and with the tap changer in the position equivalent to the rated no-load voltage. Measure the voltages between the LV phases themselves and to the earth.

For safety reasons we strongly advise against measuring directly on the LV transformer terminals. If these voltages deviate from the rated no-load voltage, it can be adjusted (see procedure below). The transformer is left with no load for a few hours. During this period the sound, temperature and liquid levels – if visible – are checked regularly.

- > The transformer may now run under load. . However, it is recommended that the transformer be left to settle for 1 to 2 days after installation. A gradually increasing load with intermediate checks is recommended.
- > Adjusting the low voltage. If the voltage on the LV side both at no load and under load deviates from the rated value and this must be adjusted, the procedure is as follows:
 - De-energize the transformer at the HV and LV side and earth it properly;
 - Unlock the tap changer by lifting the knob;
 - Change the tap changer to the desired position;
 - Release the knob until the spring presses it down again and thus re-locks the tap changer.

Low voltage too high (must be decreased)

If the applied high voltage is higher than the rated transformer high voltage, this results in the low voltage being too high.

In this case the HV tap changer knob should be put in a position that corresponds to a high voltage that is higher than the rated high voltage (see rating plate). The tap changer must be set at a lower position number.

Low voltage too low (must be increased)

If the applied high voltage is lower than the rated transformer high voltage this results in the low voltage being too low.

In this case the HV tap changer knob should be put in a position that corresponds to a high voltage that is lower than the rated high voltage (see rating plate). The tap changer must be set at a higher position number.

Increasing low voltage (higher tap changer knob position number compared with reference value) Decreasing low voltage (lower tap changer knob position number compared with reference value)

Example (see rating plate)

	Position no. tap changer	HV Volt	LV Volt	
	1	15,500		
	2	15,250		
Rated position	3	15,000	400	Rated voltage
	4	14,750		
	5	14,500		

3.4. Parallel operation

When running in parallel, the transformers must satisfy the relevant regulations and conditions (including IEC 60076-1 and IEC 60076-8, see Chapter 4).

These are the following:

- > Transformers must have the same clock-hour number. The winding connections may be different;
- > Impedance voltages must be the same (a tolerance of maximum 10% is allowed);
- > Rated voltages must be equal (both HV and LV);
- > When continuously running in parallel, the power rating ratio must not exceed 3:1.

The information for the above conditions can be found on the rating plate.

Before switching to parallel operation, the following procedure must be followed:

- > Connect the corresponding HV terminals;
- > Connect the corresponding LV terminals;
- > Provide a (preferably common) earthing on both transformer tanks;
- > Connect the LV neutrals;
- > Connect the transformers to the supply system at the HV side. The LV main switches must remain open;
- > Check for any difference in voltage between the corresponding LV phases. The voltmeter should show no readings. If, however, there is a difference in voltage, the cause should be traced and remedied;
- > If there is no difference in voltage between the corresponding LV terminals, the main lower voltage busbars may be energized at the LV side;
- > Parallel operation of/dual LV transformers (so-called “seven bushing” transformers) is not advised;
- > If the tap changers are put out of their rated positions, make sure that both set HV values correspond (see rating plate).

If the above conditions are not satisfied, circulation currents can occur which can lead to damage to the transformer. For brief parallel operation (e.g. when switching over) this may be permitted. Consult IEC 60076-8 for more details.

We cannot be held liable for damage to transformers or electrical installations caused by faulty connections.

4. Maintenance

To achieve a long life and a good operating reliability with transformers, it is important that they are maintained properly. In connection with maintenance and inspection the instructions regarding safety distances, safety equipment, earthing and limitations as to working in live conditions should be carefully followed. Hermetically sealed distribution transformers require less maintenance and transformers with an expansion tank require extra maintenance.

4.1. Annual external check

This maintenance check can be carried out while the transformer remains energized.

Attention: keep a safe distance from energized (live) parts.

This type of maintenance comprises the following:

- > Assessing the various noises coming from the transformer;
- > Checking the ambient temperature and ventilation of the premises;
- > Checking for leaks, rust and damage;
- > Checking for dirt on the bushings, apparatus and control units;
- > Checking the color of the silica gel (if applicable);
- > Checking the liquid level via the oil level gauge (if present);
- > Checking the liquid temperature (if thermometer present);
- > Checking local temperature rises due to contact resistances on HV and LV connections (infrared temperature measurement, discolorations, ...), and;
- > Checking if the overpressure relief device has been activated (if present).

4.2. Two-yearly maintenance

This type of maintenance should be carried out while the transformer is de-energized and earthed at the HV and LV sides. Also don't forget to switch off the auxiliary voltage for the accessories!

Two-yearly maintenance comprises the following:

- > Performing the annual external check (see 4.1.);
- > Remediating the comments from the yearly external inspection;
- > Checking the compound level in the HV cable junction box (if applicable);
- > Opening the HV and LV air cable boxes (if applicable), checking for condensation and water penetration;
- > Checking the auxiliary devices and accessories (correct operation, setting and checking of the contacts, cabling, checking of test equipment), and;
- > Checking the correct operation of the tap changer. The tap changer is tested whilst the transformer is de-energized by switching the tap changer into various positions and by measuring whether there is continuity in the internal connections.

We advise transformer users to adjust the above maintenance frequency if the transformers are located in severe weather conditions or direct exposure to cold, heat, direct radiation from sun, moisture and/or if the operating conditions allow or require a different frequency.

5. Liquid sampling and analysis

Having capability for performing oil samples and the analysis thereof is an owner's pre-requisite for correct use of a transformers. Any user should ensure to have such capability in place. Analysis of the sample of cooling liquid helps determine the condition of the transformer liquid and can also give an indication of the condition of the windings, (tap changer) switch and internal connections.

Sampling should best be left up to qualified personnel.

The sampling procedure, described in standards IEC 60475 and IEC 60567, must be followed strictly.

Sampling of hermetically sealed transformers whilst in service (= energized) is not allowed.

After a sample of the liquid has been taken, the level must be checked without opening the transformer if possible, and if necessary or in case of doubt it must be adjusted by authorized Pauwels Transformers' personnel.

Pauwels Transformers NV advises a 5-yearly liquid analysis for hermetically sealed transformers and a 2-yearly liquid analysis for transformers with an expansion tank. This can be adjusted if the results obtained indicate the necessity of this or if operating conditions allow or require it. We advise transformer users to adjust the above sampling and analysis frequency if the transformers are located in severe weather conditions or direct exposure to cold, heat, direct radiation from sun, moisture and/or if the operating conditions allow or require a higher frequency

Attention: **Never** top up with another type of liquid than the original type of liquid in the transformer!

6. Pauwels Transformers NV After Sales Service

For specialized work we recommend you to use the Pauwels transformers After Sales Service department. Pauwels transformers offers qualified personnel and the necessary equipment to carry out specialized jobs adequately.

Included in specialized work are:

- > Replacement of bushings, appliances and monitoring equipment;
- > Opening the transformers (transformer can be under overpressure or underpressure!);
- > Handling and replacing the cooling liquid;
- > Sealing off transformer tank leaks;
- > Carrying out electrical measurements and their interpretation, and;
- > Interpretation of analysis of liquid samples.

Contact us 24/7 at:

- > Phone +32 15 283 333
- > E-mail: services@pauwels.com

7. Accessories

At the customer's request the transformers can be fitted with a large variety of apparatus and control equipment.

More information on this (description, operation, ...) can be found on the <PK> sheets which are available upon request, or in the relevant standards.

<u>Documentation:</u>	(list not complete)	
Valves/taps	Oil drain/sampling tap	PK 3835
	Sampling valve NW 15	PK 3812
Temperature	Dial thermometer 2 contacts	PK 3544
	Dial thermometer without contacts	PK 3849
	Distance thermometer 2 contacts	PK 3546
	Thermostat 2 contacts	PK 3611
	Thermostat 1 contact	PK 3612
Liquid level gauges	Magnetic oil level 1 1/2"	PK 3519
	Level gauge expansion tank DIN 42555	PK 3511
	Oil level gauge	PK 3514
	Oil level indicator 1" (float type)	PK 3527
Pressure	Pressure relief valve 1"	PK 3735
	Pressure relief relay 2 contacts	PK 3733
Expansion tank	Buchholz relay BG 25, 2 contacts	PK 3710
	Air dryer	PK 3750
		PK 3751
	Vent/filling opening of expansion tank	DIN 42553
Other	DGPT 2	PK 3760
	Oil level switch	PK 3520
Bushings	LV bushings 1 kV	EN 50386
	LV busbar bushings 1 kV	EN 50387
	LV bushings 3 kV	DIN 42539
	HV bushings 12-24-36 kV	EN 50180
LV Connectors for terminal studs		DIN 43675
Current carrying connections up to 1600 A		DIN 46200
Plug-in bushings		EN 50180

8. Standards

For more information on transformers in general you can have a look at the following IEC and CENELEC standards:

IEC 60076	Power Transformers
> IEC 60076-1	General
> IEC 60076-2	Temperature rise
> IEC 60076-3	Insulation levels, dielectric tests and external clearances in air
> IEC 60076-5	Ability to withstand short-circuit
> IEC 60076-7	Loading guide for oil-immersed power transformers
> IEC 60076-8	Application guide
> IEC 60076-10	Determination of sound levels
> IEC 60076-14	Liquid-immersed power transformers using high-temperature insulation materials
> IEC 60076-20	Energy efficiency
> IEC 60076-22 (*)	Power transformers and reactor fittings
IEC 60616	Terminal & tapping markings for power transformers
IEC 60296	Specification for unused mineral insulating oils for transformers and switchgear
IEC 60422	Supervision and maintenance guide for mineral insulating oils in electrical equipment
IEC 60475	Method of sampling liquid dielectrics
IEC 60567	Guide for the sampling of gases and of oil from oil-filled electrical equipment and for the analysis of free and dissolved gases
IEC 60599	Mineral oil-impregnated electrical equipment in service - Guide to the interpretation of dissolved and free gases analysis
IEC 60836	Specifications for silicone liquids for electrical purposes
IEC 60944	Guide for the maintenance of silicone transformer liquids
IEC 61099	Specification for unused synthetic organic esters for electrical purposes
IEC 61203	Synthetic organic esters for electrical purposes - Guide for maintenance of transformer esters in equipment
IEC 62770	Fluids for electrotechnical applications - Unused natural esters for transformers and similar electrical equipment
IEC 62950	Natural esters - Guidelines for maintenance and use in electrical equipment
EN 60076 (*)	Identical to IEC 60076
EN 50180	Bushings above 1kV up to 36kV and from 250A to 3150A for liquid-filled transformers
EN 50216 (*)	Power transformer and reactor fittings
EN 50464 (*)	Three-phase oil-immersed distribution transformers 50Hz, from 50 to 2500kVA with highest voltage for equipment not exceeding 36kV
EN 50386	Bushings up to 1kV and from 250A to 5kA for liquid-filled transformers
EN 50387	Busbar bushings up to 1 kV and from 1,25 kA to 5 kA, for liquid filled transformers
EN 50708 (*)	Power Transformers – additional European requirements

(*) series with several subparts

9. End of life

The transformer is constructed in such a way that the different components can easily be recycled at the end of its life span.

However, the components can only be recycled after the cooling liquid has been drained. The latter should be done with great care.

The indicative relation between the different transformer materials is the following:

> Cooling liquid	25%
> Core material	35%
> Winding material (copper and/or aluminum)	15%
> Steel	20%
> Insulation material	5%

The insulation material is to be regarded as non-toxic waste.

The transformer does not contain any PCBs, or PCTs, PCBTs or asbestos.

Annex 1: Insulation resistance measurement (Megger test)

The Megger test measures the insulation resistance between the HV and LV windings and between the windings and the earth. Any short-circuit to the earth or low insulation resistance due to the presence of water in oil and windings or because of a high dissipation factor of the liquid can be detected in this way.

The following instructions shall be observed when carrying out this measurement:

- > Remove HV and LV connections from the bushings;
- > Clean the bushings;
- > Carry out the measurement in dry conditions (no rain, fog, snow,...);
- > Carry out the measurement by measuring directly on the transformer terminals;
- > After each measurement the transformer should be discharged (extremely dangerous capacitive voltage!);
- > The transformer tank must be correctly connected to the earth.

Measuring procedure:

3 measurements are carried out, preferably with an electronic megger.

For use and settings of the measuring device and to read (*) the scale values: check the appropriate manual.

- > HV to earth with 5000 or 2500 Volt (**)
- > LV to earth with 2500 Volt (**), and
- > HV to LV with 5000 or 2500 Volt (**)

(*) Value should be read when the meter needle is stable (generally after 1 minute).

(**) The voltage applied during megger testing must never exceed the test voltage of the transformer.

Measurement may be carried out on any HV and LV phase as the three phases are interconnected internally.

If the values measured are less than **10 MOhm/kV**, the cause must be established.

For example:

For a transformer with a rated high voltage of 15 kV the values must be minimum $10 \times 15 = 150$ MOhm (also for the low voltage).

Remark:

In case the cooling fluid used is an ester, then the measured insulation resistance will be less than compared to mineral oil. In case of doubt, please contact Pauwels Transformers. See also the value mentioned on the test certificate.

Having capability for performing insulation resistance measurement (megger test) and the analysis thereof is an owner's pre-requisite for correct use of a transformer. Any user/owner should ensure and/or procure to have such capability in place.

Annex 2: Recommended torque values (Nm) for various connections

Thread size	M6	M8	M10	M12	M16	M20	M30	M42	M48	> M55
Spanner size	10	13	17	19	24	30	46	65	75	75/85
A/ Bushings										
Low voltage (LV)										
1. Fixing of bushing stem (13a) : DIN 42530 EN 50386 with buna and cork				250A		630A	1000A/ 1250A	1800A/ 2000A	3150A	4000A/ 5000A
				7-12 12		25-40 20	65-100 55-60	100-150 70-75	100-150 100-120	100-150 125-145
2. Connection between nuts (13b/c)				15-20		70-100	250-350			
3. Fixing of flag connector to terminal stem (bolt in stainless steel) (6a) - with cup washer			25-35	40-60	90-120					
				50-70						
4. Connection to flag surface (6b) (Bolts 8.8 steel)			40-50	65-85	100-180					
5. Connection monobloc on frame With buna and cork				20-30						
High Voltage (HV)										
1. Fixing of top terminal stem (9a) (terminal and nut in brass)				10-15		22-55				
2. Connection to terminal stem (9 b/c) (terminal stud and 2 nuts in brass)				15-20						
3. Fixing of base (12) (stud and nut in stainless steel) With buna and cork			10-20	20-35						
B/ LV connecting busbar										
Interconnection (bolt in 8.8 steel)			40-50	65-85	100-180					
C/ Lid / frame										
Bolt and nut in stainless steel New: M14 ; 120Nm			35-45	40-60						
D/ Busbar bushings										
Fixing on the lid										
Top piece onto bottom piece (M6)		8-15	25-40							
	3.5	10	20							
E/ Valves										
Gasket IT (bolt and nut A2 with cup washer)						100-130				
F/ Flanges										
Gasket IT (bolt and nut A2 with cup washer)						100-130				
G/ Connection box on cover										
Threaded stud and nut A2 with cup washer		12-15								

Remark:

Min Value : Checking torque

Max Value : max applied torque

If the torque that you measure is lower than Min Value -> re-apply Max torque Value

Checking recommended torque values is required:

- > When installing the transformer;
- > When connecting the cables and/or bars to the HV/LV connectors of the transformer;
- > When carrying out maintenance work.

We recommend re-applying Max. Torque Value 4 weeks after replacement of the gaskets.

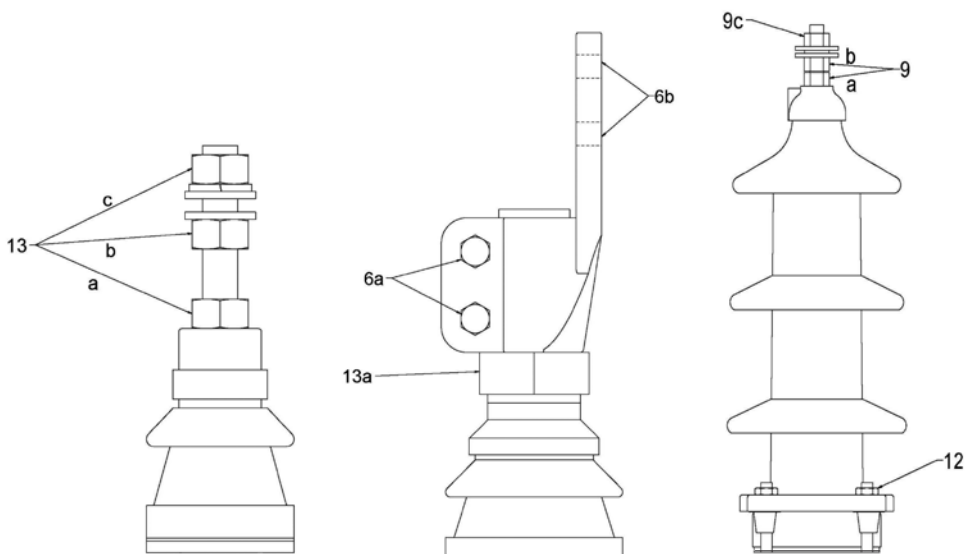

LV bushings

HV bushings



Contact us 24/7 at:

- > Phone +32 15 283 333
- > E-mail: services@pauwels.com